

TOOLS REQUIRED

- Rechargeable, variable speed drill
- 3/8" diameter drill bit
- 3" Robertson bits #0, #1 and #2
- Slot screwdriver
- Non marring hammer with 1" head
- Level
- Caulk or sealant for both mitered corners and to cover gaps between the frames and window jambs
- Pencil
- Loctite glue 414 or contact cement required for outside mount L-frame applications
- Jig Saw, Hack saw, Dremmel Tool or exacto knife if cut-outs are required

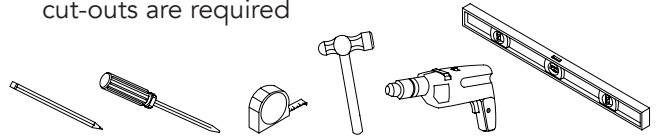

INSIDE MOUNT WITHOUT FRAME (DIRECT MOUNT)

1. Install top hinge

- Starting with the left panel, place panel into opening.
- With the hinge leafs secured to the panel, position the panel so it has equal clearance at the top and bottom.
- Make a pencil mark at the bottom of the top hinge.
- Place hinge leaf below the pencil mark on the window frame. Install one screw (#6 x 5/8") into the hinge securing it to the window frame.
- Check to see if the position is accurate by placing the panel into the opening and inserting the hinge pin into the hinge.
- If accurate, remove the panel and set the second screw (#6 x 5/8") into the top hinge and move to the installation of the bottom hinge.
- If the position of the panel is not correct, adjust the position of the hinge leaf attached to the window opening and check again for accurate positioning.

Note: Front to back positioning of the hinge leaf varies based on the type of hinge leaf being used for this application. Standard 5/8" Hinge Leaf – the barrel of the hinge should be just in front of the edge of the window frame. 1 1/4" Extended Leaf Hinge – the barrel of the hinge should extend approximately 1/2" past the front edge of the window frame.

2. Install bottom hinge

- Place the panel into position by inserting the hinge pin into the top hinge.
- Make a pencil mark on the window jamb below the bottom hinge and remove panel.
- Install one screw (#6 x 5/8") into the bottom leaf of the bottom hinge.
- Check the position is accurate by setting the panel back in the opening and inserting the hinge pins in both the top and bottom hinges.
- If accurate, remove panel and install second screw (#6 x 5/8") in bottom hinge.
- If the position of the panel is not correct, adjust the position of the bottom hinge and check again for accurate positioning.

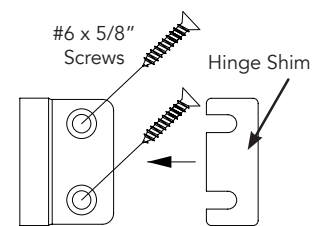

Fig. 1.1

Note: In most cases the window frames are not plumb. Hinge shims will likely be needed to properly align hinges and allow proper panel operation. (See Fig. 1.1)

3. Level Panels

- If there are more panels in the same opening, repeat the first two steps with lining up the panels as the main concern.
- If minor support or leveling is required, turn adjustable jamb cap at the bottom of the vertical jamb (stile) to the required spot. (See Fig. 1.2)

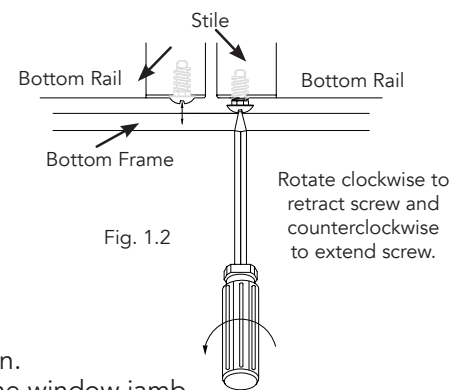

Fig. 1.2

4. Install Remaining Hinges

- Once panels are level, install the remaining hinges while the panels are hanging.
- Simply open the panel(s), and insert hinge pins into all hinges.
- One at a time, slide a hinge leaf up onto the bottom of an intermediate hinge pin.
- Hold the leaf so that it is positioned against the leaf attached to the panel and the window jamb.
- Set both screws and use hinge shims when necessary. Repeat the above steps for all remaining hinges.

5. Install catch system

- If Magnets were requested, see Magnet & Catch Placement section on page 9 for installation details.
- If Panel Lock was requested, see Panel Lock Ramp Installation on page 9.

FRAME ASSEMBLY

1. Labels

- All Frames will be identified with removable labels. Match the line number of the frame to the line number of the panel. Do not remove labels until product is installed.

2. Frame Assembly

- Lay frame sides flat beside the panels to ensure that the frames will be assembled correctly and that the hinges on the panels and the frames will be in alignment.
- Frames should be pre-drilled with installation holes. If not, pre-drill all frame sides using a 3/8" drill bit. Drill through the first layer of Polyresin 3 only.
- Installation holes are located just below each hinge on the side frames (except bottom hole is located just above the bottom hinge). Top and bottom frames should have evenly spaced holes no more than 16" apart. (See Fig. 2.2)
- Insert the plastic corner keys into both ends of the top and bottom frames. Note: Bonding is only required for an outside mount L-frame application. (see step #3)
- Slide the corner key that is in the top and bottom frames into the end of each side frame.
- Using a rubber mallet hammer, give a firm tap to the frame to ensure the corner keys are fully engaged.

Note: Casing Frame cover strip may be requested. If ordered, the cover strip must be slid onto the bottom of the frame prior to assembly.

3. Glue Corner Keys (Outside Mount L-Frame Only)

- Apply Loctite 414 (or Contact Cement) to inside surface of the corner key cavity of both frame corners to be assembled.
- Insert the corner key, making sure the mitered corner is clean, tight and in alignment. Hold firmly till set (10 to 20 seconds). (See Fig. 2.1)
- Repeat for remaining corners.

Note: It will be impossible to detach the corners after the adhesive has set.

4. Metal L Brackets

- The Bullnose Z Frame, S Frame, Casing Frame, Trim Frame, and Deluxe Trim Frame will also include metal L Brackets which are attached to the back side of the frame.
- With the frame face down, set a metal L Bracket on the back of the frame in each corner. (See Fig. 2.3)
- Using the supplied screws (#6 x 5/8"), set 4 screws in each bracket to firmly secure the corners.
- If minor gaps appear, use caulk or sealant to seal the corners once the shutter is completely installed.

Apply Loctite 414 to outside surface of corner key cavity.

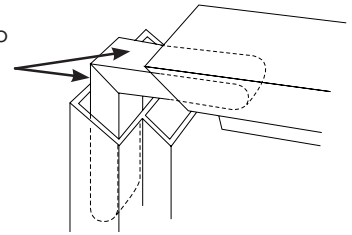
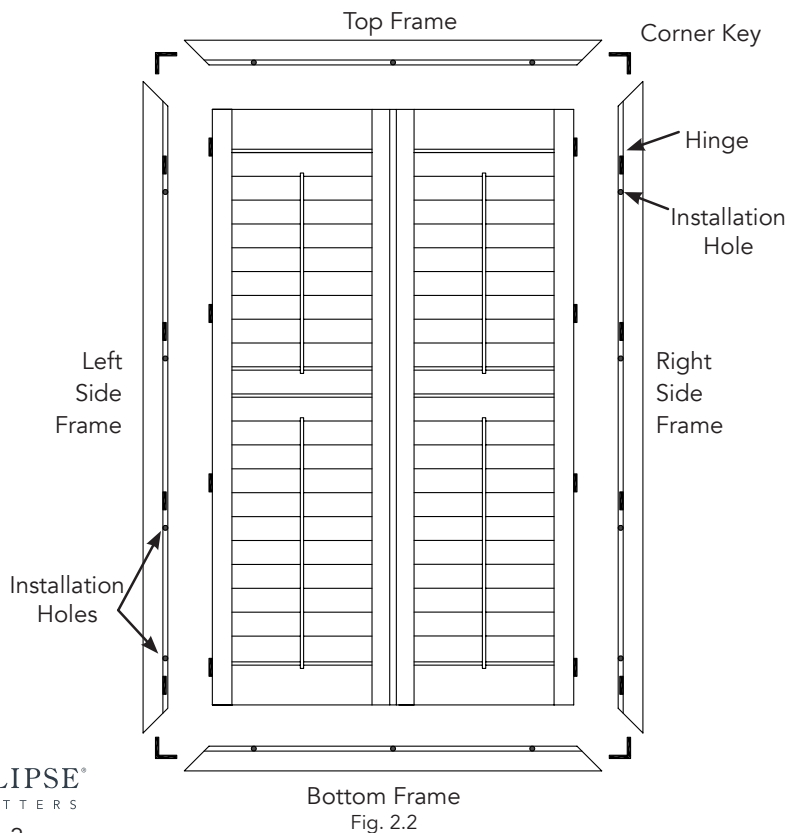

Fig. 2.1



Metal bracket installed on back side of Bullnose Z Frame, S Frame, Trim Frame, Deluxe Trim Frame and Casing Frame.

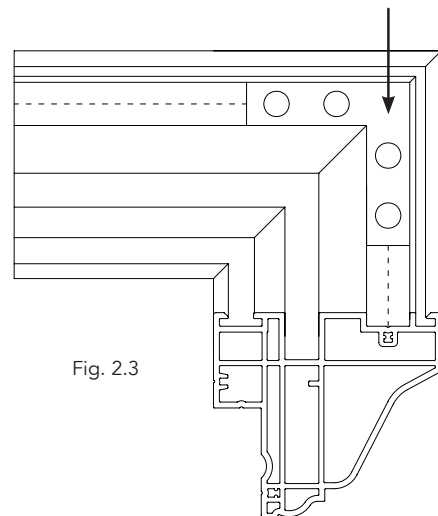

Fig. 2.3

INSIDE MOUNT WITH L FRAME

1. Place frame in opening

- Make sure the frame has been properly assembled and is right side up. Labels will identify each frame piece.

2. Fasten frame

- Center the frame in the opening. Insert screws (#8 x 1 1/2") into the pre-drilled holes on the top of each side frame. Set the screws into the window jambs.

Note: If the frame is significantly smaller than the opening size, then do not overtighten the screws. Overtightening the screws will cause the frame to distort.

3. Hang panels

- Set the panel(s) in the frame and insert the hinge pins of the top and bottom hinges only.

4. Square or level panels to the opening (See Fig. 3.1)

- Move bottom frame left or right until the panels are level. If this does not work then;
- Remove the top left screw and move the left frame side up or down until the panels are level. Once level, set the screw back into the window opening. If this does not work then; try repeating for the right side frame. (An alternate option to this step is to remove the top right installation screw. Loosen or tighten the top left side screw until the panels are level then re-install the top right screw.)
- When the panels are level and square within the frame, hold the bottom frame in position and set a screw in the middle bottom frame hole. (Note: Setting a bottom screw may not be possible due to marble window sills, etc. If this is the case, set screws in the lower side frame holes.)
- When magnets are supplied, minor support or leveling can be achieved by turning the adjustable jamb cap at the bottom of the vertical jamb (stile) to the required spot. (See Fig. 1.2)

5. Fasten remaining screws

- Insert screws in the remaining holes and check to ensure panels are level after every screw has been set into position.

6. Panel Lock & Magnets

- The Panel Lock system does not require any installation when 4-sided frames are used. The Panel Lock caps have already been installed in the ends of the stiles. The plungers lock into the groove of the frame.
- If magnets were ordered, see Magnet & Catch Placement section for installation details. (See page 9)

7. Cap screw holes

- Once all screws have been installed and panels checked for level, cap all holes with the provided button plugs. (See Fig. 3.2)

8. Close Gaps

- Close gaps around frames with L-Frame Cover Strip (if requested). This is glued to the front face of the frame. (See Fig 3.2)
- Caulk or sealant can be used to seal any gaps around the frames or mitered corners.

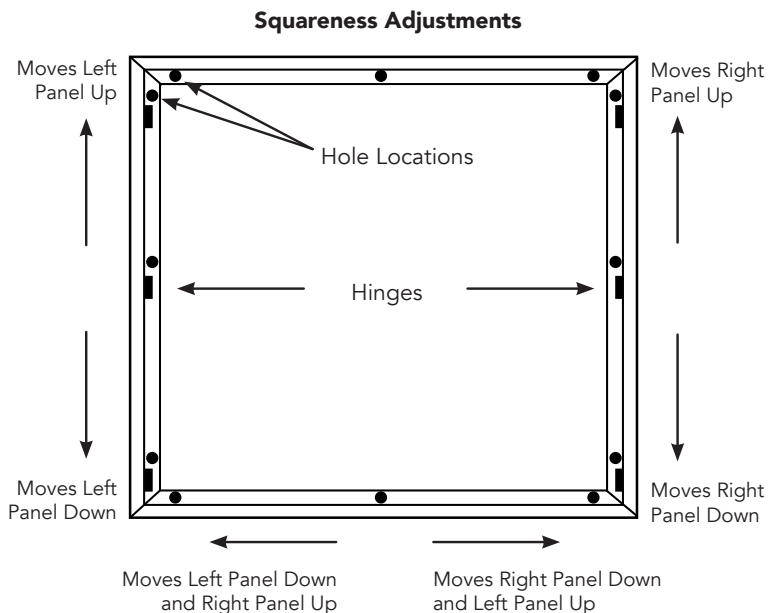

Fig. 3.1

Inside Mount L Frame with Cover Strip

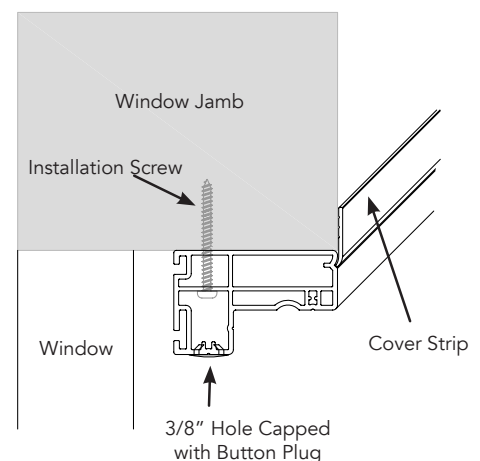

Fig. 3.2

INSIDE MOUNT WITH Z, TRIM, OR DELUXE TRIM FRAME

1. Place frame in opening

- The top of the frame is indicated by a greater amount of distance from the top of the top hinge to the edge of the frame.
- Make sure the frame has been properly assembled and is right side up. Labels will identify each frame piece.

2. Fasten frame

- Most frames have pre-drilled holes placed for ease of installation.
- Insert a screw (#8 x 1 1/2") in both the left and right top side frame holes. Center the frame in the opening, then set the screws into the window jambs.

Note: If the frame is significantly smaller than the opening size, then do not overtighten the screws. Overtightening the screws will cause the frame to distort.

3. Hang panels

- Set the panel(s) in the frame and insert the hinge pins of the top and bottom hinges only.

4. Square or level panels to the opening (See Fig. 4.1)

- Move bottom frame left or right until the panels are level. If this does not work then;
- Remove the top left screw and move the left frame side up or down until the panels are level. Once level, set the screw back into the window opening. If this does not work then; try repeating for the right side frame. (An alternate option to this step is to remove the top right installation screw. Loosen or tighten the top left side screw until the panels are level then re-install the top right screw.)
- When the panels are level and square within the frame, hold the bottom frame in position and set a screw in the middle bottom frame hole. (Note: Setting a bottom screw may not be possible due to marble window sills, etc.)
- When magnets are supplied, minor support or leveling can be achieved by turning the adjustable jamb cap at the bottom of the vertical jamb (stile) to the required spot. (See Fig. 1.2)

5. Fasten remaining screws

- Insert screws in the remaining holes and check to ensure panels are level after every screw has been drilled into position.

6. Panel Lock & Magnets

- The Panel Lock system does not require any installation when 4-sided frames are used. The Panel Lock caps have already been installed in the ends of the stiles. The plungers lock into the groove of the frame.
- If magnets were ordered, see Magnet & Catch Placement section on page 9 for installation details.

7. Cap screw holes

- Once all screws have been installed and panels checked for levelness, cap all holes with the provided button plugs. (See Fig. 4.2)

8. Close any gaps

- Dap or Caulking can be used to seal any gaps around the frames or mitered corners.

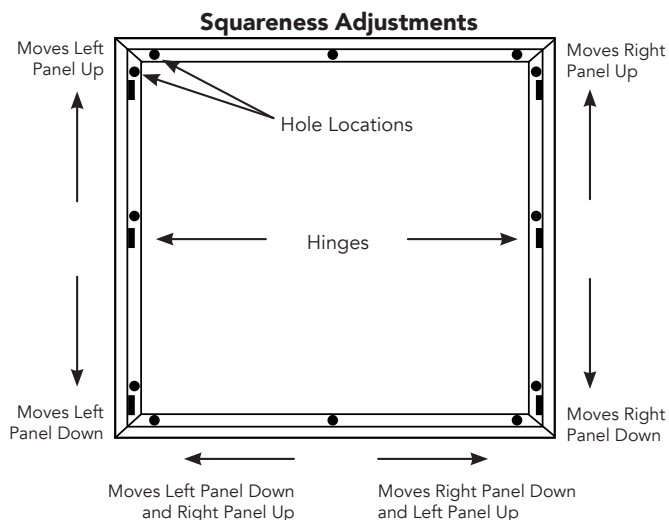

Fig. 4.1

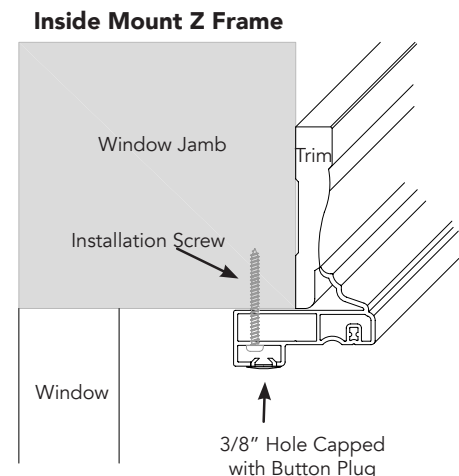

Fig. 4.2

INSIDE MOUNT WITH HANG STRIP

1. Drill installation holes

- 3/8" diameter holes must be drilled at each hinge location. (See Fig. 5.1)

2. Place side frame in opening

- The top part of the frame is indicated by a greater amount of distance from the top of the top hinge to the edge of the frame.
- The label will indicate left and right side.

3. Fasten hinge side hang strip

- Insert a screw (#8 x 1 1/2") inside the top hole first, followed by the bottom, keeping the hang strip plumb.

4. Hang panels

- Set the panel(s) in the opening and insert the hinge pins of the top and bottom hinges only.

5. Square or level panels to the opening

- Adjust the bent leaf hinges, if necessary. (See Fig. 5.1)
- Loosen the hinge screws and move the hinge left or right.
- Re-tighten screws once level.
- If the panels cannot be leveled or squared by adjusting the hinges, then use shims behind the hang strip to achieve the desired results.

6. Fasten remaining screws

- Insert screws in the remaining holes.
- Check to ensure panels are level after every screw has been screwed into position.

7. Fasten top and bottom light stop

- Drill 3/8" holes about 5" from each end of each piece of light stop.
- Space intermediate holes evenly about every 12"-16".
- Center and insert screws.

8. Cap screw holes

- Once all screws have been installed and panels checked for levelness, cap all holes with the provided button plugs.

9. Install magnets and plates

- See Magnet & Catch Placement section on page 9 for installation details.

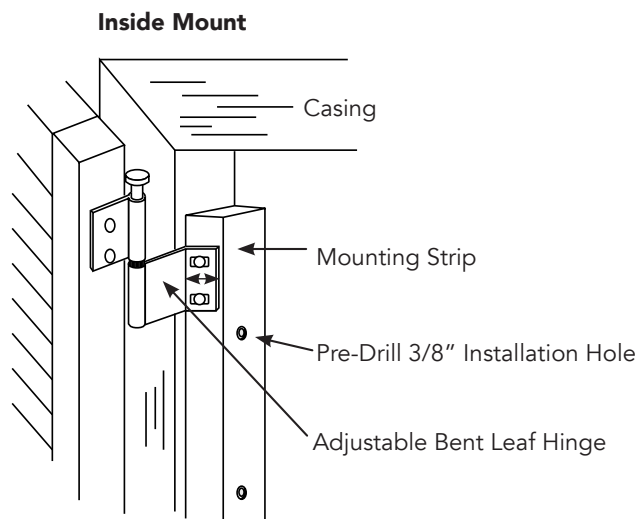

Fig. 5.1

OUTSIDE MOUNT WITH S FRAME, L FRAME AND CASING FRAME

1. Hold frame on opening

- Make sure the frame has been properly assembled and is right side up. The top of the frame is indicated by a greater amount of distance from the top of the top hinge to the edge of the frame.

2. Fasten frame

- Insert a screw (#8 x 1 1/2") in both the left and right top side frame holes. Secure the left screw first. Make sure the frame is level and then secure the screw on the right. Depending on the application and number of extensions, longer #8 x 2" screws may be supplied.

3. Hang panels

- Set panel(s) in the frame and insert the hinge pins of the top and bottom hinges only.

4. Square or level panels to the opening (See Fig. 6.1)

- Move bottom frame left or right until the panels are level. If this does not work then;
- Move left frame up or down until the panels are level. If this does not work then;
- Move right frame up or down until the panels are level.
- When the panels are level within the frame, hold the bottom frame in position and place a screw in the middle bottom frame hole. Make sure the bottom frame is level before setting screws.
- If minor support or leveling is required, turn adjustable jamb cap at the bottom of the vertical jamb stile to the required spot. (See Fig. 1.2)

5. Fasten remaining screws

- Insert screws in the remaining holes.
- Check to ensure panels are level after every screw has been screwed into position.

6. Panel Lock & Magnets

- The Panel Lock system does not require any installation when 4-sided frames are used. The Panel Lock caps have already been installed in the ends of the stiles. The plungers lock into the groove of the frame.
- If magnets were ordered, see Magnet & Catch Placement section on page 9 for installation details.

7. Cap screw holes

- Once all screws have been installed and panels checked for level, cap all holes with the provided button plugs. (See Fig. 6.2)

8. Close any gaps

- Caulking or sealant can be used to seal any gaps around the frames or mitered corners.

Squareness Adjustments

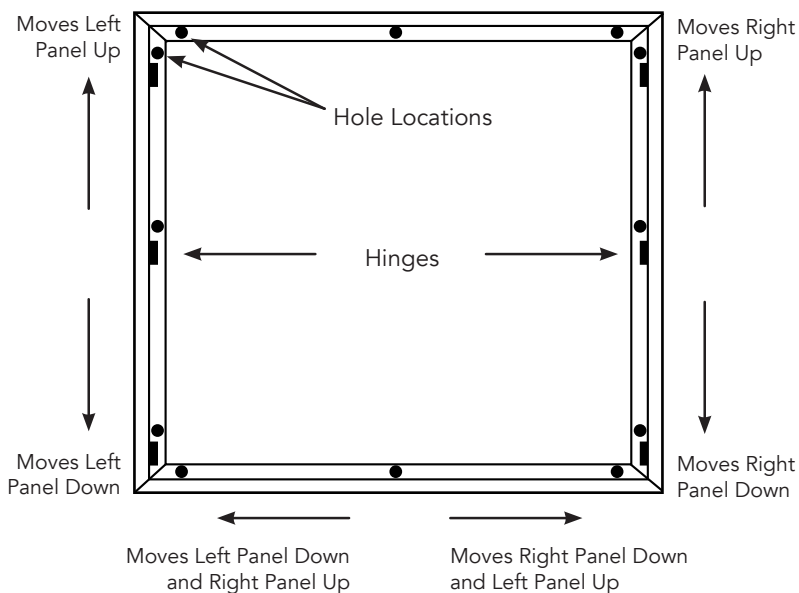

Fig. 6.1

Outside Mount Casing Frame

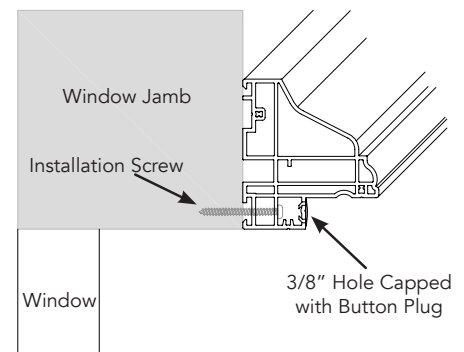

Fig. 6.2

T POST INSTALLATION

1. MOUNTING DIRECTLY TO WINDOW MULLIONS

- Drill 3/8" holes through the first layer of Polyresin 3 in the front face of the T-Post. Start approximately 2" from the top and drill additional holes approximately every 10-15 inches.
- Secure the T-Post by screwing in the top and bottom holes making sure that the T-Post is plumb.
- Hang panels from the T-Post to ensure even sight lines and all is level.
- If no adjustments are needed, then install the remaining screws.
- Cap all holes with button plugs.

2. MOUNTING USING T POST BLOCKS (4 Sided Frame)

- The frames will be pre-drilled with the assembly holes in the frames.
- Lay out the top and bottom frames so that the light block is facing up on both.
- Stack two T Post Alignment Blocks, both with the tabs facing down. (See Fig. 7.1)
- Position the stacked blocks on the light block portion of the frame so that the holes in the blocks align with the pre-drilled holes in the frame. (The tabs will hang off the inside edge of the light block.) (See Fig. 7.1)
- Using (2) #6 x 1 3/4" T Post block screws, attach the blocks to each frame. Do not completely tighten the screws down, only make them snug. This will allow some side to side adjustment of the T Post. (See Fig. 7.2)
- Insert the corner keys into the top and bottom frames. Attach the left side frame to the top frame, followed by the right side frame to the top frame.
- Attach T Post to the top frame by sliding the T Post over the blocks on the top frame, then attach the bottom. Make sure the T Post is positioned over the blocks and the corner keys align with the side frames.
- Follow standard instructions for installing the frame.
- Test the fit and position of the panels to determine the location of the T Post.
- Mark the position of the T Post on the frame with a pencil.
- Remove the panels.
- With the bottom of the T Post in the desired position, drive a #8 x 1 1/2" installation screw horizontally through the pre-drilled hole in the end of the T Post. (See Fig. 7.3)
- The screw will then pass between the (2) T Post Blocks, thus locking the T Post into position.
- Repeat for the top of the T Post and cap installation holes with button plugs.

Attach T Post Blocks to Frame

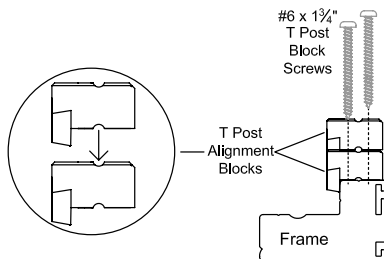

Fig. 7.1

Position T Post

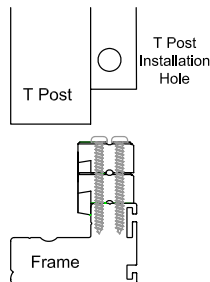

Fig. 7.2

Align T Post and Secure

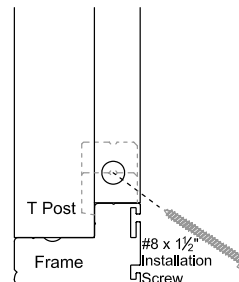

Fig. 7.3

T Post Alignment Block

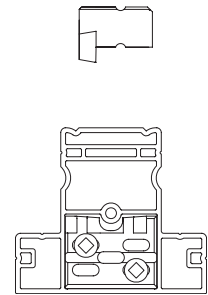

Fig. 7.4

3. MOUNTING USING T POST BLOCKS (3 Sided Frame)

- The frames will be pre-drilled with the assembly holes in the frames.
- Lay out the top frame so that the light block is facing up.
- Stack two T Post Alignment Blocks, both with the tabs facing down. (See Fig. 7.1)
- Position the stacked blocks on the light block portion of the frame so that the holes in the blocks align with the pre-drilled holes in the frame. (The tabs will hang off the inside edge of the light block.) (See Fig. 7.1)
- Using (2) #6 x 1 3/4" T Post block screws, attach the blocks to the frame. Do not completely tighten the screws down, only make them snug. This will allow some side to side adjustment of the T Post.
- Insert the corner keys into the top frame. Attach the left side frame to the top frame, followed by the right side frame to the top frame.
- Attach T Post to the top frame by sliding the T Post over the blocks on the top frame.
- Begin by installing the shutter as a standard 3-sided frame but install only the top screw on each side frame and one bottom screw if necessary.
- Test the fit and position of the panels to determine the location of the T Post.
- Mark the front and center of the T Post with a pencil on the sill.
- Mark the back of the T Post with a pencil on the sill.

Continued on next page.

T POST INSTALLATION CONTINUED

- Remove the panels and the frame.
- Stack two T Post Alignment Blocks, one with the tab facing up and one with the tab facing down. (See Fig. 8.2)
- Attach two stacked T Post blocks to the sill so that the back of the "trough" of the block is 1 1/4" from the front center mark of the T Post. (See Fig. 8.1)
- Use (2) #6 x 1 3/4" T Post Block Screws to attach the blocks to the sill. Do not fully tighten the screws – they should only be snug. (See Fig. 8.3)
- Set the assembled frame back in the opening making sure the bottom of the T Post slides over the blocks on the sill. (See Fig. 8.3)
- Finish installing the frame and then hang the panels.
- Determine the side to side position of the T Post, then drive a #8 x 1 1/2" installation screw horizontally through the pre-drilled hole in the end of the T Post.
- The screw will then pass between the (2) T Post Blocks, thus locking the T Post into position. (See Fig. 8.4)
- Repeat for the opposite end of the T Post and cap installation holes with button plugs.

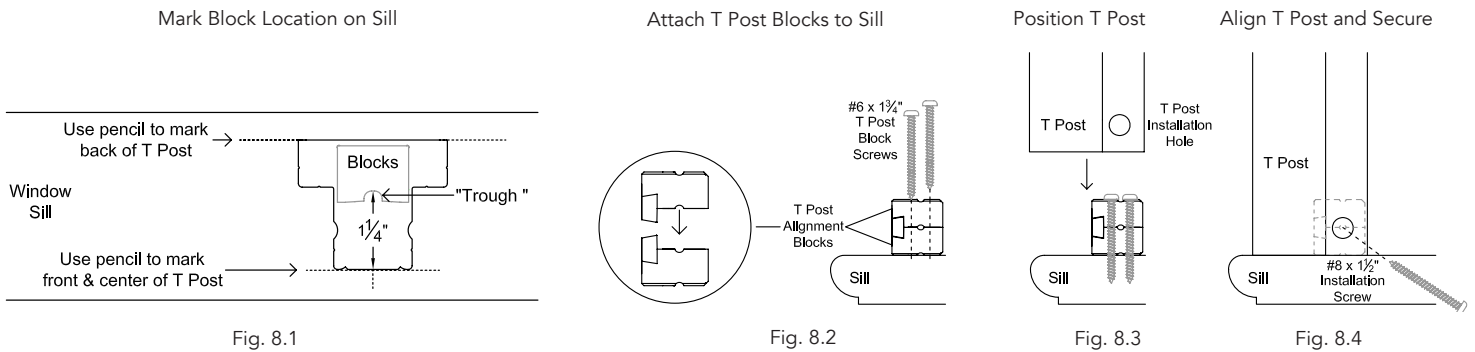

4. MOUNTING USING L-BRACKETS

- L Brackets can also be used to secure a T-Post to a frame or window opening. One side of the bracket includes a small round hole called a Stop Hole and the other side includes an elongated hole called a Slot Hole. (See Fig. 8.5)
- Attach the first L-Bracket to the top right side of the T-Post. The Stop Hole should be positioned against the T-Post and the side with the Slot hole will face up. (See Fig. 8.6)
- Attach the second L Bracket to the bottom left side of the T-Post. The Stop Hole should be positioned against the T-Post and the side with the Slot hole will face down. (See Fig. 8.6)
- Use the screw indicator line on the side of the T Post to determine the position of the brackets.
- Position the T-Post in the opening or frame.
- Set screws through the Slot Holes of the T Post Brackets into the opening or frame. Center the screw into the Slot Hole of the L-Bracket. This will allow some side to side play for leveling purposes.
- Hang panels and adjust T-Post positioning until sight lines and leveling is achieved.
- Lock T-Post into position by attaching the third and fourth L Brackets. These brackets will be located at the top left and bottom right of the T-Post.
- The side of the L Bracket with the Slot Hole will be attached to the T-Post and the side with the Stop Hole will be attached to the frame or window opening. (See Fig. 8.6)
- Set remaining screws to securely lock the T Post into position.

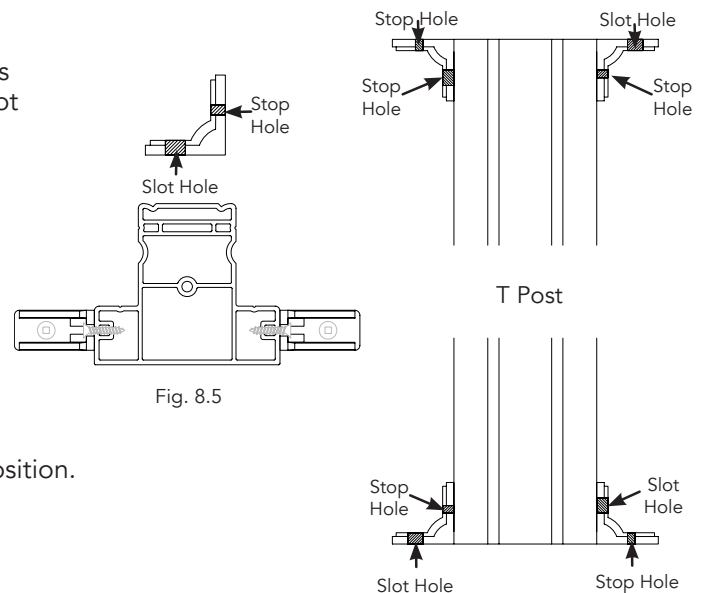

PANEL LOCK RAMP INSTALLATION

- Once the shutter and panels have been installed, make a mark on the frame with a pencil to show where the center of the Panel Lock Plunger is located. (See Fig. 9.1)
- Open the panel(s)
- Place the Panel Lock Ramp on sill or window frame. The front edge of ramp should be set back 1/8" from the front of the panel.
- Center the ramp on the line marking the plunger location. (See Fig. 9.2)
- Mark the center of each screw hole of each Ramp.
- Remove the Ramps and drill a pilot hole for each screw using a 3/32" drill bit.
- Place the Ramp back on the frame and set the screws (#6 x 5/8"). Repeat as necessary. (See Fig. 9.2)
- Operate the panel(s) to ensure proper function and closure.
- The Panel Lock Plunger can be adjusted by using a flat head screwdriver. Push in on the plunger and rotate clockwise to thread the plunger into the panel or rotate the plunger counterclockwise to extend the plunger.

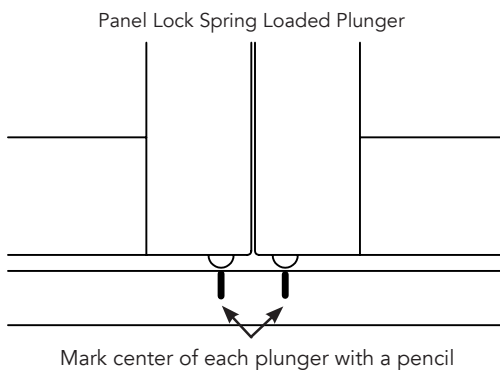

Fig. 9.1

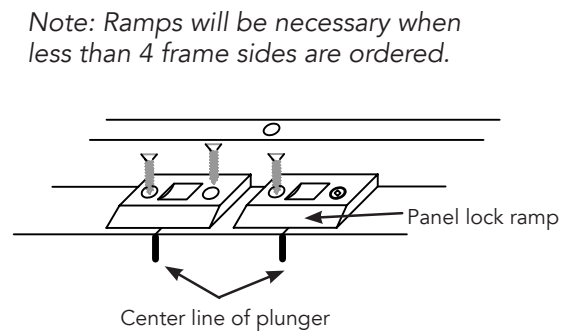

Fig. 9.2

MAGNET CATCH PLACEMENT

- Install catch plate first as shown on drawings with the holes towards the center of panel. (See Fig. 9.3)
- Each catch plate should be 3/8" away from the edge of the stile and 3/8" away from the end of the panel. (See Fig. 9.3)
- With panels in the closed position, pencil mark the sill or frame where the stile meets the cross rail.
- Install magnet from the mark toward the inside of the panel.
- Install two magnetic catches per panel. (See Fig. 9.4)

On framed applications, mount plate 3/8" from stile **(A)**, and 3/8" from end of panel on top rail **(B)**.

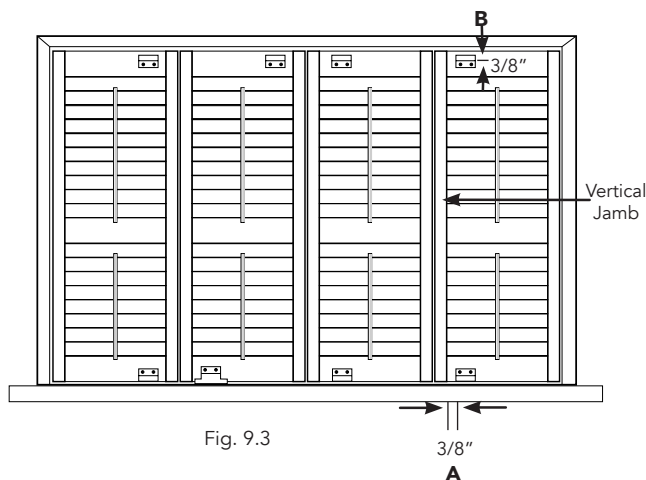

Fig. 9.3

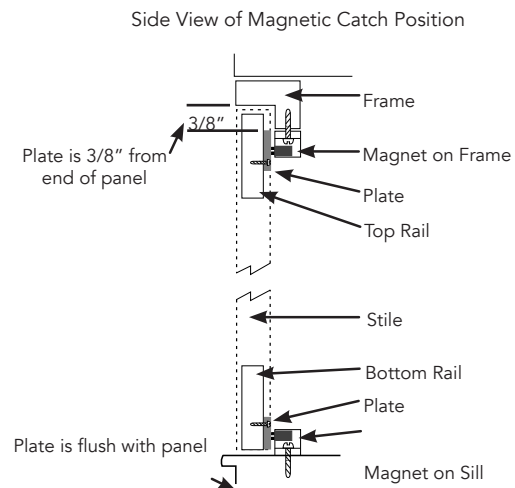

Fig. 9.4

Note: All magnetic catches must be installed. Mount magnets on frames. When there is no frame, mount magnets on window sill or jamb. Receiver plate mounts on bottom and top cross rails.